

FLOUR ROLLER MILL

“Kharkovchanka - 800plus”

MODEL NO.3545 MK

Technical characteristics

Productivity of grain	kg/h	800
Flour output in all	%, to	73
incl. high grade	to	60..63
1 grade		8..12
2 grade		2..5
Installed power	kW	85
Air consumption	m ³ /h	5230
Average water consumption	l/h	40
Attendants	men	2
Height	mm	6196
(length and width are on the planning)		
Weight, not more	ton	8



Planning

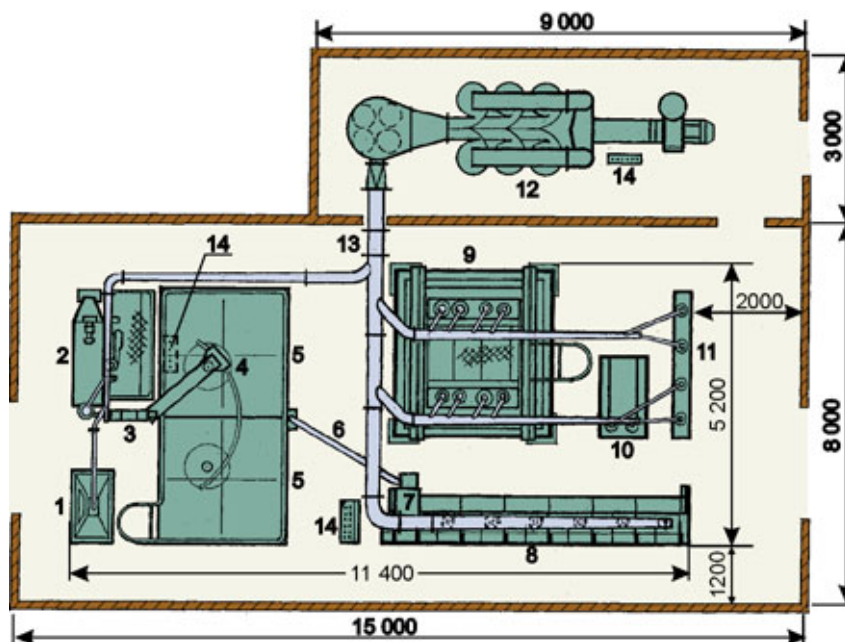

- | | |
|---|---------------------------------------|
| 1. Receiving bunker | 10. Double drum duster |
| 2. Grain cleaning unit | 11. Bran and flour unloading conveyer |
| 3. Paternoster | 12. Air cleaning unit |
| 4. Rotary moisturizer | 13. Collector |
| 5. Grain binning bunker | 14. Control console |
| 6. Grainpipe | |
| 7. Brushing machine | |
| 8. Roller device | |
| (7 two-roller machines $\varnothing 250 \times 400$) | |
| 9. Plansifter RPS4-17 | |

Additional equipment:

Bagger-weigher

Equipment placing on production spaces is fulfilled after agreement with the Customer

